

CRN Type Room Instructor Hrs. Units Days Begin-End

ENGLISH

ENGL 1A Composition

Transferable: CSU, UC; CSU-GE:A2, IGETC:1A; GAV-GE:A2; CAN:ENGL2, ENGL SEQ A

This is a writing course which emphasizes expository writing, argumentative writing, and critical reading of expository prose. It is meant to train students in clear thinking and reasoned support of ideas. Students will be given the opportunity to read models of good expository and argumentative prose and learn the techniques of good writing. These include choosing appropriate subjects, developing restricted, unified, and precise theses and presenting supporting evidence in a logical, lucid, and effective manner. To achieve this end, students write no fewer than six essays and read at least five works, two of which are book length. PREREQUISITE: English 250 and English 260 or English 250 and SSCI 270A or English 250 and SSCI 270B with a grade of 'C' or better or satisfactory score on the English placement examination.

Tutorial help is offered for the following classes. See your instructor.

40307 Online Wisdom K 3.0

 This online class will be delivered entirely over the Internet. After enrolling, start the class by going to <http://www.gavilan.edu/disted>, and log into the system. Students who have not logged in by 5 pm on the 3rd day may be dropped from the class.

40309 Online Chaffin C 3.0

 This online class will be delivered entirely over the Internet. After enrolling, start the class by going to <http://www.gavilan.edu/disted>, and log into the system. Students who have not logged in by 5 pm on the 3rd day may be dropped from the class.

40316 Online Crook E 3.0

 Lec SS206 Crook E 1.6 T 0945-1105
This HYBRID lecture/online class will be delivered partially over the internet. See the online syllabus for details. <http://www.gavilan.edu/dised/>

40326 Online Crook E 3.0

 Lec SS206 Crook E 1.6 R 0945-1105
This HYBRID lecture/online class will be delivered partially over the internet. See the online syllabus for details. <http://www.gavilan.edu/dised/>

40311 Lec SS203 Pirani A 3.2 3.0 MW 0810-0930

40312 Lec PB3 Condon D 3.2 3.0 TR 0810-0930

40313 Lec MHG4 Bragger M 3.2 3.0 MW 0810-0930

Above class meets at Morgan Hill Community site.

40314 Lec HOL5 Mora G 3.3 3.0 F 0900-1205

Above class meets at the Hollister Briggs site.

40315 Lec HOL1 Mora G 3.2 3.0 MW 0230-0350

Above class meets at the Hollister Briggs site.

40317 Lec SS205 Lanoie C 3.3 3.0 F 0900-1205

⑨ 40318 Lec PB3 Salvin C 3.2 3.0 MW 1120-1240

⑬ 40320 Lec PB3 Hirasuna S 3.2 3.0 TR 1250-0210

⑫ 40321 Lec SS203 Schessler S 3.2 3.0 MW 1250-0210

⑫ 40323 Lec SS203 Schessler S 3.2 3.0 MW 0230-0350

40324 Lec SS203 Estrada-Mack T 3.2 3.0 TR 0400-0520

⑤ 40328 Lec HOL1 Brett T 3.3 3.0 W 0600-0905

Above class meets at the Hollister Briggs site. Tutorial help is offered for this class.

40329 Lec SS203 Pirani A 3.3 3.0 T 0600-0905

40330 Lec MHG3 Kovacs M 3.3 3.0 M 0600-0905

Above class meets at Morgan Hill Community site.

PUENTE LEARNING COMMUNITY ENGL 1A CLASS:

① 40319 Lec SS206 Sandler S 3.2 3.0 TR 1120-1240

Students enrolling in this class will participate in the PUENTE Program. Required: Complete an application with the Puente counselor prior to registration. This class is part of a learning community. Student must also enroll in GUID 1, CRN 40004. See ad on this page.

Have you met the prerequisite?

It's required!

Choose a **THEME** for your English class:

Find the number, by the course section number, that corresponds to a theme below.

- ① Explore American consumerism and wild alternatives.
- ② Explore the great American classics.
- ③ Explore how literature can both forge new entry points and maintain existing boundaries between individuals and communities. Focus on images of race, ethnicity, gender and sexuality in classic plays, American poetry and modern fiction.
- ④ Explore the great literature of the human condition, challenging you to respond to literary art, science fiction, music, tragedy and the joy of life and living.
- ⑤ Explore the exciting realm of science and discover who we are, how we got here, and learn about the scientists and explorers who got us here while learning to write with panache, flair and accuracy.
- ⑥ Learn to think, to think courageously, to think intelligently and to think for yourself through challenging the pseudoscientific, the paranormal, the make-believe world of nutty beliefs and scams.
- ⑦ Investigate urgent social issues through contemporary literature.
- ⑧ Take a different look at the wars we all think we know, through the literature and personal accounts of writers such as John Steinbeck, Eve Ensler and Lousi DeBernais.
- ⑨ Investigate environmental issues, particularly those connected to what we eat and where we live.
- ⑩ First Year Experience: Explore the issues of peace and conflict through reading and writing.
- ⑪ Puente: Develop writing skills through an emphasis on Chicano/Latino literature.
- ⑫ Develop expository writing skills in response to issues of war and the experiences of soldiers during combat and after they return home.
- ⑬ Develop expository writing skills in response to literary works from a rich diversity of cultures.
- ⑭ Develop expository writing skills in response to American literary works about "madness" by analyzing memoirs, fiction, poems, and film.



The Puente Project is a two-semester program that combines three components: writing, counseling and mentoring to support students to transfer to four-year universities and colleges. The Guidance 1 course focuses on self assessment and career development. The English 1A course focuses on Mexican American/Latino literature. The program also includes a student leadership conference, university visits and mentor/student socials. The program is open to all eligible students. For more information, call Celia Marquez, Puente Co-Coordinator at 408-848-4807.

Required: Complete a program application with the Puente Counselor prior to registration.

ENGL1A CRN 40319 SS206 SANDLER S TuTh 1120A-1240P

GUID 1 CRN 40004 CH101 MARQUEZ C MW 1120A-1240P



Students will need to complete 10 hours of mentoring.

CRN Type Room Instructor Hrs. Units Days Begin-End

ENGL 1B Composition and Literature**Transferable:** CSU, UC; CSU-GE:C, IGETC:3B; GAV-GE:C2; CAN:ENGL4, ENGL SEQ A

English 1B continues the work begun in 1A, but now the emphasis shifts to writing expository prose in conjunction with reading and analyzing imaginative literature. Students are to write as fledgling critics and use the text as a basis for other forms of reflection. The reading requirement includes short stories, poetry, drama, and at least two novels. Course work will also include fundamentals of research writing. **PREREQUISITE:** English 1A with a grade of "C" or better.



Tutorial help is offered for the following classes. See your instructor.

40332	Online		Raimondo J	3.0				
 This online class will be delivered entirely over the Internet. After enrolling, start the class by going to http://www.gavilan.edu/disted , and log into the system. Students who have not logged in by 5 pm on the 3rd day may be dropped from the class.								
40334	Online		Raimondo J	3.0				
 This online class will be delivered entirely over the Internet. After enrolling, start the class by going to http://www.gavilan.edu/disted , and log into the system. Students who have not logged in by 5 pm on the 3rd day may be dropped from the class.								
40341	Online		Warren K	3.0				
 This online class will be delivered entirely over the Internet. After enrolling, start the class by going to http://www.gavilan.edu/disted , and log into the system. Students who have not logged in by 5 pm on the 3rd day may be dropped from the class.								
3	40337	Lec	PB14	Smith K	3.2	3.0	TR	0945-1105
	40339	Lec	SS203	Osikomaiya J	3.3	3.0	F	1100-0205
14	40340	Lec	SS203	Schessler S	3.2	3.0	MW	1120-1240
7	40342	Lec	HOL5	Salvin C	3.2	3.0	TR	1120-1240
Above class meets at the Hollister Briggs site.								
2	40350	Lec	PB14	Luoma D	3.2	3.0	MW	1250-0210
	40351	Lec	PB14	Estrada-Mack T	3.2	3.0	TR	0230-0350
8	40335	Lec	MHG13	Oral M	3.2	3.0	MW	0400-0520
Above class meets at Morgan Hill Community site.								
4	40352	Lec	PB3	Brett T	3.3	3.0	R	0600-0905

ENGL 1C Critical Reasoning and Writing**Transferable:** CSU, UC; CSU-GE:A3, IGETC:1B; GAV-GE:C2

This course is designed to develop critical thinking, reading, and writing skills beyond the level achieved in English 1A. The emphasis is on critical analysis of arguments and the development of the ability to integrate the principles of critical thinking into essay writing. **PREREQUISITE:** English 1A with a grade of "C" or better.

Tutorial help is offered for the following classes. See your instructor.

40353	Online		Chaffin C	3.0				
 This online class will be delivered entirely over the Internet. After enrolling, start the class by going to http://www.gavilan.edu/disted , and log into the system. Students who have not logged in by 5 pm on the 3rd day may be dropped from the class.								
40360	Online		Wisdom K	3.0				
 This online class will be delivered entirely over the Internet. After enrolling, start the class by going to http://www.gavilan.edu/disted , and log into the system. Students who have not logged in by 5 pm on the 3rd day may be dropped from the class.								
	40354	Lec	PB14	Oral M	3.2	3.0	MW	0810-0930
	40356	Lec	SS111	Condon D	3.2	3.0	TR	1120-1240
	40361	Lec	MHG10	Oral M	3.2	3.0	MW	1120-1240
Above class meets at Morgan Hill Community site.								
	40357	Lec	PB14	Luoma D	3.2	3.0	MW	0230-0350
	40355	Lec	HOL1	Mora G	3.2	3.0	MW	0400-0520
Above class meets at the Hollister Briggs site.								
	40358	Lec	PB3	Luoma D	3.2	3.0	TR	0400-0520
6	40359	Lec	PB3	Brett T	3.3	3.0	M	0600-0905

**Brush Up your Software Skills**

Most Computer Applications classes are repeatable.

CRN Type Room Instructor Hrs. Units Days Begin-End

ENGL 2C Introduction to Film and Fiction**Transferable:** CSU, UC; CSU-GE:C2, IGETC:3B; GAV-GE:C2

This is a literature course in analysis of the novel and film as art forms. The student will read several novels, view the films based on the novels, and discuss the difference in techniques, both orally and in writing. **PREREQUISITE:** Eligible for English 1A.

40362 Lec SS214 Richards G 3.3 3.0 W 0630-0935

ENGL 2J Mythology**Transferable:** CSU, UC; CSU-GE:C2, IGETC:3B; GAV-GE:C2

This course is a survey of myths from around the world, with an emphasis on literary analysis of the myths. The course covers the purposes and types of myths; the development of myths and mythological characters, the recurring elements of mythological structures, the influence of mythology on contemporary texts. **PREREQUISITE:** Eligible for English 1A.

40363 Lec SS110 Warren K 3.2 3.0 TR 1120-1240

ENGL 4B British Literature - 1798 to Present**Transferable:** CSU, UC; CSU-GE:C2, IGETC:3B; GAV-GE:C2; CAN:ENGL10, ENGL SEQ B

This course is a study of the masters of British Literature from 1798 to present. In this course we will read and analyze the literature of Blake, Wordsworth, Coleridge, Byron, Shelley, Keats, Tennyson, Browning, Arnold, Clough, Hopkins, Rossetti, Bronte, Yeats, Joyce, Woolf, Lawrence, Eliot, and Forster. Note: this course need not be taken in sequence. **PREREQUISITE:** Eligible for English 1A.

40371 Lec SS111 Sandler S 3.2 3.0 MW 1120-1240

ENGL 9A Introduction to Creative Writing**Transferable:** CSU, UC; CSU-GE:C2; GAV-GE:C2; CAN:ENGL6

This course includes the writing, reading, and critical discussions of various forms of poetry and fiction. **PREREQUISITE:** Eligible for English 1A.

40374 Lec SS111 Smith K 3.6 3.0 TR 1250-0220

40377 Lec MHG3 Frazier S 3.3 3.0 R 0600-0905
Above class meets at Morgan Hill Community site.**ENGL 9B Advanced Creative Writing****Transferable:** CSU, UC; CSU-GE:C2; GAV-GE:C2

This class is a continuation of English 9A, with the emphasis shifting to publication. The genre of non-fiction will be the primary focus, but the genres of fiction will also be taught at a more comprehensive level than in English 9A. The process of finding a market for one's work will be followed step by step. The class may compile and publish "Soaring", Gavilan's literary magazine, each spring semester. **PREREQUISITE:** English 9A with a grade of credit or C or better.

40375 Lec SS111 Smith K 3.6 3.0 TR 1250-0220

40378 Lec MHG3 Frazier S 3.3 3.0 R 0600-0905
Above class meets at Morgan Hill Community site.**ENGL 9C Poetry Writing****Transferable:** CSU, UC; CSU-GE:C2; GAV-GE:C2

This course includes the writing, reading, and critical discussions of various forms of poetry. **PREREQUISITE:** English 9A with a grade of credit or C or better.

40376 Lec SS111 Smith K 3.6 3.0 TR 1250-0220

40380 Lec MHG3 Frazier S 3.3 3.0 R 0600-0905
Above class meets at Morgan Hill Community site.**ENGL 12A Tutoring Writers: Training/Theory & Practice****Transferable:** CSU

Fundamentals of compositional theory, the writing process, peer-to-peer communication, interacting with faculty and educational institutions and effective responses to writing will be covered. In addition, students will gain an understanding of the basic history, methodology and practice of writing pedagogy while developing a writing community that aids in connecting them to their own writing practice. **ADVISORY:** Eligible for English 1A.

40387 Lec LI120 Smith K 1.8 1.0 M 0230-0400

CRN Type Room Instructor Hrs. Units Days Begin-End

ENGL 12B Tutoring Writers: Training/Theory & Practice

Transferable: CSU

Fundamentals of compositional theory, the writing process, peer-to-peer communication, interacting with faculty and educational institutions and effective responses to writing will be covered. In addition, students will gain an understanding of the basic history, methodology and practice of writing pedagogy while developing a writing community that aids in connecting them to their own writing practice. ADVISORY: Eligible for English 1A.

40389 Lec LI120 Smith K 1.8 1.0 M 0230-0400

ENGL 12C Tutoring Writers: Training/Theory & Practice

Transferable: CSU

Fundamentals of compositional theory, the writing process, peer-to-peer communication, interacting with faculty and educational institutions and effective responses to writing will be covered. In addition, students will gain an understanding of the basic history, methodology and practice of writing pedagogy while developing a writing community that aids in connecting them to their own writing practice. ADVISORY: Eligible for English 1A.

40392 Lec LI120 Smith K 1.8 1.0 M 0230-0400

ENGL 12D Tutoring Writers: Training, Theory & Practice

Transferable: CSU

Fundamentals of compositional theory, the writing process, peer-to-peer communication, interacting with faculty and educational institutions and effective responses to writing will be covered. In addition, students will gain an understanding of the basic history, methodology and practice of writing pedagogy while developing a writing community that aids in connecting them to their own writing practice. ADVISORY: Eligible for English 1A.

40393 Lec LI120 Smith K 1.8 1.0 M 0230-0400

ENGL 23 Independent Study

Transferable: CSU

Designed to afford selected students specialized opportunities for exploring areas at the independent study level. The courses may involve extensive library work, research in the community, or special projects. May be repeated until six units of credit are accrued. This course has the option of a letter grade or pass/no pass. REQUIRED: The study outline prepared by the student and the instructor must be filed with the department and the dean.

40412	Ind	LI120	Smith K	2.0
40413	Ind	LI120	Smith K	1.0
40482	Ind	SS109	Warren K	1.0
40483	Ind	SS109	Warren K	2.0

ENGL 250 Practical Writing

Transferable: No; GAV-GE:A2

This course covers writing clear, correct, effective essays and learning preliminary research skills. PREREQUISITE: English 440 or ESL 563 with a grade of 'C' or better or satisfactory score on the English placement examination.

Tutorial help is offered for the following classes. See your instructor.

40415	Lec	PB3	Sandler S	3.2	3.0	MW	0810-0930
	Lab	LI120	Sandler S	1.0		T	0810-0900

This service learning course section involves community work

40417	Lec	PB3	Sandler S	3.2	3.0	MW	0810-0930
	Lab	LI120	Sandler S	1.0		R	0810-0900

This service learning course section involves community work

40420	Lec	PB14	Osikomaiya J	3.2	3.0	TR	0810-0930
	Lab	LI120	Osikomaiya J	1.0		F	0810-0900

40421	Lec	PB14	Osikomaiya J	3.2	3.0	TR	0810-0930
	Lab	LI120	Osikomaiya J	1.0		F	0910-1000

① 40422	Lec	PB3	Salvin C	3.2	3.0	MW	0945-1105
	Lab	LI120	Salvin C	1.0		M	0845-0935

① 40423	Lec	PB3	Salvin C	3.2	3.0	MW	0945-1105
	Lab	LI120	Salvin C	1.0		W	0845-0935

① Your ENGL 250 class
② has a theme.
③ See list on page 65.

continued

Introduction to Film & Fiction

ENGL 2C



CRN #40362
Wednesday
6:30 pm - 9:35 pm
Instructor - Grant Richards

The DaVinci Code
Pride and Prejudice
Million Dollar Baby
Mystic River
A History of Violence
Cold Mountain
Sideways
Motorcycle Diaries
Closer
Fight Club
Notebook
High Fidelity
The Shawshank Redemption
To Kill a Mockingbird
One Flew Over the Cuckoo's Nest
Chocolat
LA Confidential
Get Shorty
and more!

This class can fulfill your IGETC humanities transfer requirement.

ENGL 2J Mythology

CRN #40363
Tu/Th, 11:20 am - 12:40 pm
Instructor: Karen Warren

An exploration of figures and themes from world mythologies, from classical times to the present

Transferable to UC and CSU.
Satisfies the Humanities requirement under both the CSU and IGETC GE patterns.



This class can fulfill your IGETC humanities transfer requirement.

ENGL 4B

British Literature

499 to 1798 A.D.

CRN #40371
MW 11:20 am - 12:40 pm
Instructor: Scott Sandler

CRN	Type	Room	Instructor	Hrs.	Units	Days	Begin-End
ENGL 250 Practical Writing <i>cont.inued</i>							
① 40424	Lec	HOL1	Salvin C	3.2	3.0	TR	0945-1105
	Lab	HOL1	Salvin C	1.0		T	0845-0935
Above class meets at the Hollister Briggs site.							
① 40425	Lec	HOL1	Salvin C	3.2	3.0	TR	0945-1105
	Lab	HOL1	Salvin C	1.0		R	0845-0935
Above class meets at the Hollister Briggs site.							
40426	Lec	SS203	Richards G	3.2	3.0	TR	0945-1105
	Lab	LI171	Richards G	1.0		T	1120-1210
40427	Lec	SS203	Richards G	3.2	3.0	TR	0945-1105
	Lab	LI171	Richards G	1.0		R	1120-1210
40428	Lec	MHG11	Hooper J	3.2	3.0	MW	0945-1105
	Lab	MHG8	Hooper J	1.0		M	1115-1205
Above class meets at Morgan Hill Community site.							
40429	Lec	MHG11	Hooper J	3.2	3.0	MW	0945-1105
	Lab	MHG10	Hooper J	1.0		W	1115-1205
Above class meets at Morgan Hill Community site.							
40432	Lec	PB3	White S	3.2	3.0	MW	1250-0210
	Lab	LI171	White S	1.0		F	1210-0100
40433	Lec	PB3	White S	3.2	3.0	MW	1250-0210
	Lab	LI171	White S	1.0		F	0110-0200
40436	Lec	PB3	Hooper J	3.2	3.0	MW	0400-0520
	Lab	LI171	Hooper J	1.0		M	0300-0350
40437	Lec	PB3	Hooper J	3.2	3.0	MW	0400-0520
	Lab	LI171	Hooper J	1.0		W	0300-0350
40438	Lec	SS203	Arora S	3.2	3.0	MW	0700-0820
	Lab	SS203	Arora S	1.0		W	0830-0920
40439	Lec	SS203	Arora S	3.2	3.0	MW	0700-0820
	Lab	SS203	Arora S	1.0		M	0830-0920

CRN	Type	Room	Instructor	Hrs.	Units	Days	Begin-End
ENGL 250 Practical Writing <i>cont.inued</i>							
Tutorial help is offered for the following classes. See your instructor.							
40440	Lec	HOL5	Parker V	3.2	3.0	MW	0700-0820
	Lab	HOL5	Parker V	1.0		M	0830-0920
Above class meets at the Hollister Briggs site.							
40441	Lec	HOL5	Parker V	3.2	3.0	MW	0700-0820
	Lab	HOL5	Parker V	1.0		W	0830-0920
Above class meets at the Hollister Briggs site.							
40442	Lec	MHG3	Frazier S	3.2	3.0	TR	0400-0520
	Lab	MHG3	Frazier S	1.0		T	0530-0620
Above class meets at Morgan Hill Community site.							
40443	Lec	MHG3	Frazier S	3.2	3.0	TR	0400-0520
	Lab	MHG3	Frazier S	1.0		R	0300-0350
Above class meets at Morgan Hill Community site.							

FIRST YEAR EXPERIENCE ENGL 250 CLASSES:

⑩ 40430	Lec	PB14	Gatewood J	3.2	3.0	TR	1120-1240
	Lab	LI120	Gatewood J	1.0		T	0230-0320
This class is part of a First Year Experience Learning Community. If you enroll you must also enroll in ENGL 260, # 40449.							
⑩ 40431	Lec	PB14	Gatewood J	3.2	3.0	TR	1120-1240
	Lab	LI120	Gatewood J	1.0		R	0230-0320
This class is part of a First Year Experience Learning Community. If you enroll you must also enroll in ENGL 260, # 40450.							
⑩ 40434	Lec	PB3	Gatewood J	3.2	3.0	TR	0945-1105
	Lab	LI120	Gatewood J	1.0		T	1250-0140
This class is part of a First Year Experience Learning Community. If you enroll you must also enroll in ENGL 260, # 40446.							
⑩ 40435	Lec	PB3	Gatewood J	3.2	3.0	TR	0945-1105
	Lab	LI120	Gatewood J	1.0		R	1250-0140
This class is part of a First Year Experience Learning Community. If you enroll you must also enroll in ENGL 260, # 40447.							

ENGLISH COMPOSITION AND READING COURSE SEQUENCE

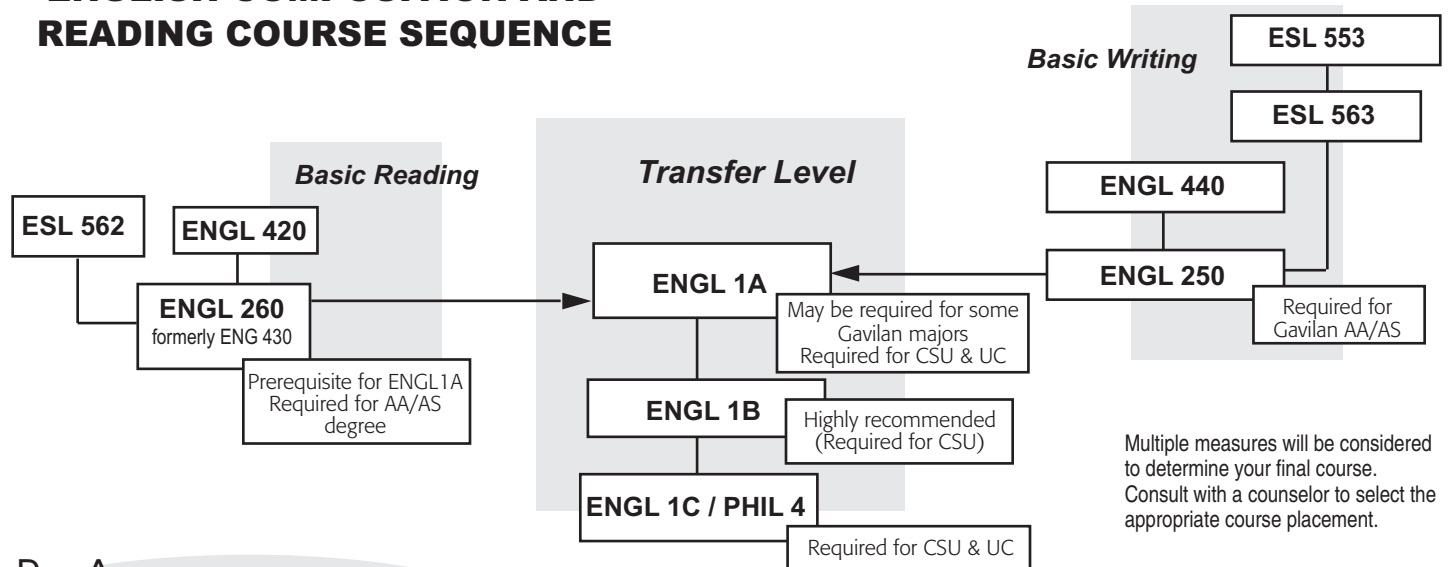

Be Aware

You MAY NOT take courses that overlap (courses that meet at the same day and time)!

CRN Type Room Instructor Hrs. Units Days Begin-End

ENGL 260 Preparation for College Reading

Transferable: No; GAV-GE:A3

This is a course presenting strategies in the technique and practice of college level critical reading and thinking skills.

PREREQUISITE: Completion of English 420 or ESL 562 with a grade of 'C' or better or Assessment recommendation.

1 Your ENGL 260
2 class has a theme.
3 See list on page 65.

Tutorial help is offered for the following classes. See your instructor.

40444	Lec	SS203	Hull K	3.2	3.0	TR	0810-0930
40445	Lec	SS203	Hull K	3.2	3.0	MW	0945-1105
40448	Lec	PB3	Withers M	3.3	3.0	F	1010-0115
40451	Lec	PH102	Hull K	3.2	3.0	MW	1120-1240
40452	Lec	SS203	Arora S	3.2	3.0	MW	0530-0650
40453	Lec	HOL5	Parker V	3.2	3.0	MW	0530-0650

Above class meets at the Hollister Briggs site.

FIRST YEAR EXPERIENCE ENGL 260 CLASSES:

- ⑩ 40446 Lec PB3 Hooper J 3.2 3.0 TR 1120-1240
This class is part of a First Year Experience Learning Community. If you enroll you must also enroll in ENGL 250, # 40434.
- ⑩ 40447 Lec PB3 Hooper J 3.2 3.0 TR 1120-1240
This class is part of a First Year Experience Learning Community. If you enroll you must also enroll in ENGL 250, # 40435.
- ⑩ 40449 Lec PB14 Hooper J 3.2 3.0 TR 1250-0210
This class is part of a First Year Experience Learning Community. If you enroll you must also enroll in ENGL 250, # 40430.
- ⑩ 40450 Lec PB14 Hooper J 3.2 3.0 TR 1250-0210
This class is part of a First Year Experience Learning Community. If you enroll you must also enroll in ENGL 250, # 40431.

ENGL 420 Reading Improvement

Transferable: No

This is a practical, "how to" course teaching various methods of learning and reading college material. Using group and individual instruction in vocabulary, comprehension, and study skills, the students will increase their ability to survive academically, to profit, grow and succeed in all college courses, and to enjoy reading and learning. Units earned in this course do not count toward the associate degree and/or certain certificate requirements. PREREQUISITE: Satisfactory score on the English placement examination.

Tutorial help is offered for the following classes. See your instructor.

40456	Lec	SS111	Tracey I	3.2	3.0	MW	0810-0930
	Lab	SS216	Tracey I	1.0		F	0810-0900
40457	Lec	SS111	Tracey I	3.2	3.0	MW	0810-0930
	Lab	SS216	Tracey I	1.0		F	0910-1000
40458	Lec	HOL1	Roscher J	3.2	3.0	MW	0945-1105
	Lab	HOL1	Roscher J	1.0		F	0910-1000
Above class meets at the Hollister Briggs site.							
40459	Lec	HOL1	Roscher J	3.2	3.0	MW	0945-1105
	Lab	HOL1	Roscher J	1.0		F	1010-1100
Above class meets at the Hollister Briggs site.							
40460	Lec	SS111	Hirasuna S	3.2	3.0	TR	0945-1105
	Lab	LI120	Hirasuna S	1.0		R	1115-1205
40461	Lec	SS111	Hirasuna S	3.2	3.0	TR	0945-1105
	Lab	LI120	Hirasuna S	1.0		T	1115-1205
40464	Lec	PB14	Gardner L	3.2	3.0	MW	0500-0620
	Lab	PB14	Gardner L	1.0		M	0630-0720
40465	Lec	PB14	Gardner L	3.2	3.0	MW	0500-0620
	Lab	PB14	Gardner L	1.0		W	0630-0720

↳ continued

Get College Credit for Working or Volunteering!



Cooperative Work Experience

is available to day, evening, full-time and part-time students.

If your job or volunteer work is directly related to your education or occupational goals sign up for:

CWE 190: Occupation Work Experience Education

If your job or volunteer work is not directly related to your educational goals sign up for:

CWE 192: General Work Experience Education

Call 408-846-4993 for more information.

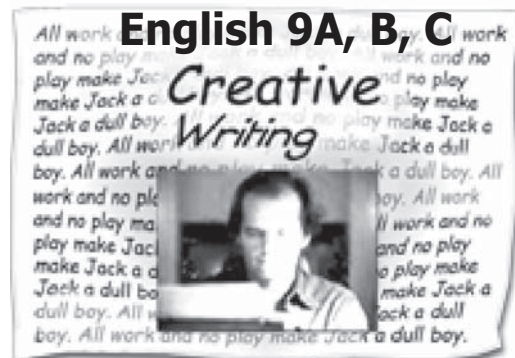

Scene from The Shining

Creative Writing classes allow students to express themselves through writing in a variety of modes: fiction, poetry, drama, and creative non-fiction.

Students will work both individually and in collaborative group activities, as well as respond to each other's work through supportive classroom workshops. Over the course of the semester, students will generate enough material to create a portfolio of their own work.

CRNs 40374, 40375, 40376

Tuesday/Thursday
from 12:50 - 2:20 pm
with Kimberly Smith

CRNs 40377, 40378, 40380

Thursday evening in Morgan Hill
from 6:00 - 9:05 pm
with Soma Frazier

This class fulfills your CSU humanities transfer requirement.

Don't forget

A counselor's signature is required if you take over 17.99 units (spring/fall) or over 5.99 units (summer).

You do not need a counselor's signature to register for a class with a prerequisite that was successfully completed at Gavilan.

CRN Type Room Instructor Hrs. Units Days Begin-End

ENGL 420 Reading Improvement *cont.inued*

FIRST YEAR EXPERIENCE ENGL 420 CLASSES:

40462 Lec PB14 Warren K 3.2 3.0 MW 0945-1105
 Lab SS216 Warren K 1.0 T 0945-1035
 This class is part of a First Year Experience Learning Community. If you enroll you must also enroll in ENGL 440, # 40471

40463 Lec PB14 Warren K 3.2 3.0 MW 0945-1105
 Lab SS216 Warren K 1.0 R 0945-1035
 This class is part of a First Year Experience Learning Community. If you enroll you must also enroll in ENGL 440, # 40472

ENGL 439 Basic Grammar and Reading

Transferable: No

This is a remediation course introducing basic reading and writing strategies, as well as study skills. Group and individual instruction will be used to build vocabulary, increase reading comprehension, develop study skills, and apply basic grammar to writing. Units earned in this course do not count toward the associate degree and/or certain certificate requirements. This is a pass/no pass course. ADVISORY: Assessment recommendation.

40466 L/L SS111 White S 3.2 4.0 MW 0945-1105
 L/L SS111 White S 3.3 F 0900-1205
 Tutorial help is offered for this class. See your instructor.

ENGL 440 Basic Writing

Transferable: No

This is an intensive study and application of basic grammar, sentence, and essay writing skills within the context of composing short essays. Units earned in this course do not count toward the associate degree and/or certain certificate requirements. PREREQUISITE: Satisfactory score on the English placement examination.

Tutorial help is offered for the following classes. See your instructor.

41068 Lec SS111 Bragger M 3.2 3.0 TR 0810-0930
 Lab LI171 Bragger M 1.0 F 0810-0900

41069 Lec SS111 Bragger M 3.2 3.0 TR 0810-0930
 Lab LI171 Bragger M 1.0 F 0910-1000

40467 Lec SS110 Crook E 3.2 3.0 MW 0945-1105
 Lab LI120 Crook E 1.0 M 1115-1205

40468 Lec SS110 Crook E 3.2 3.0 MW 0945-1105
 Lab LI120 Crook E 1.0 W 1115-1205

40469 Lec HOL1 Roscher J 3.2 3.0 MW 1120-1240
 Lab HOL1 Roscher J 1.0 F 1110-1200

Above class meets at the Hollister Briggs site.

40470 Lec HOL1 Roscher J 3.2 3.0 MW 1120-1240
 Lab HOL1 Roscher J 1.0 F 1210-0100

Above class meets at the Hollister Briggs site.

40473 Lec SS203 Crook E 3.2 3.0 TR 1120-1240
 Lab LI171 Crook E 1.0 T 1250-0140

40474 Lec SS203 Crook E 3.2 3.0 TR 1120-1240
 Lab LI171 Crook E 1.0 R 1250-0140

40475 Lec PB14 Gardner L 3.2 3.0 TR 0500-0620
 Lab PB14 Gardner L 1.0 T 0630-0720

40476 Lec PB14 Gardner L 3.2 3.0 TR 0500-0620
 Lab PB14 Gardner L 1.0 R 0630-0720

FIRST YEAR EXPERIENCE ENGL 440 CLASSES:

40471 Lec PB14 Warren K 3.2 3.0 MW 1120-1240
 Lab LI120 Warren K 1.0 M 1250-0140

This class is part of a First Year Experience Learning Community. If you enroll you must also enroll in ENGL 420, #40462.

40472 Lec PB14 Warren K 3.2 3.0 MW 1120-1240
 Lab LI120 Warren K 1.0 W 1250-0140

This class is part of a First Year Experience Learning Community. If you enroll you must also enroll in ENGL 420, # 40463.

1st Year Experience

is a program in place in many schools across the country. These programs are in response to much research supporting smaller schools, interdisciplinary studies, and community building. So what is FYE? At Gavilan, this program links fundamental courses together. By studying and working together with your classmates and instructors, you will develop a stronger network of support. Students who enroll in FYE often report higher GPA, increased involvement in school, more friends, greater ability to meet goals, and stronger critical thinking, reading, and writing abilities.

Mark your calendars! This semester we are also offering two Friday First Year Seminars from 1-3:30 February 20 and March 27.

The following classes are part of a First Year Experience learning community. You must enroll in both courses.

ENGL 250 Practical Writing

40435 Lec PB3 Gatewood J 3.2 3.0 TR 0945-1105
 Lab LI120 Gatewood J 1.0 R 1250-0140

and

ENGL 260 Preparation for College Reading

40447 Lec PB3 Hooper J 3.2 3.0 TR 1120-1240

_____ or _____

ENGL 250 Practical Writing

40434 Lec PB3 Gatewood J 3.2 3.0 TR 0945-1105
 Lab LI120 Gatewood J 1.0 T 1250-0140

and

ENGL 260 Preparation for College Reading

40446 Lec PB3 Hooper J 3.2 3.0 TR 1120-1240

_____ or _____

ENGL 250 Practical Writing

40431 Lec PB14 Gatewood J 3.2 3.0 TR 1120-1240
 Lab LI120 Gatewood J 1.0 R 0230-0320

and

ENGL 260 Preparation for College Reading

40450 Lec PB14 Hooper J 3.2 3.0 TR 1250-0210

_____ or _____

ENGL 250 Practical Writing

40430 Lec PB14 Gatewood J 3.2 3.0 TR 1120-1240
 Lab LI120 Gatewood J 1.0 T 0230-0320

and

ENGL 260 Preparation for College Reading

40449 Lec PB14 Hooper J 3.2 3.0 TR 1250-0210

Social security numbers are no longer used as student identifiers. Find your new Gavilan Student ID number and choose a log-on PIN by going to www.gavilan.edu and clicking on the Self-Service Banner icon. You will use your new ID number and PIN to log into Self-Service Banner and register for Winter Intersession and Spring classes.



FIRST YEAR EXPERIENCE cont.

Is this your first year at Gavilan? Looking for a community of people like you? Then this learning community program is specially designed for you. The first year of college can be challenging for many students. By studying and working together with your classmates and instructors, in this program you'll develop a strong network of support to help you succeed. You'll improve your reading and writing skills and also explore options for majors, transferring, and careers. Building a strong foundation in your first year will put you on the road to success throughout your college experience.

The Program: Students will take reading and writing together because these skills are needed to succeed in college classes.

The following classes are part of a First Year Experience learning community. You must enroll in both courses.

ENGL 420 Reading Improvement

40462	Lec	PB14	Warren K	3.2	3.0	MW	0945-1105
	Lab	SS216	Warren K	1.0		T	0945-1035

and

ENGL 440 Basic Writing

40471	Lec	PB14	Warren K	3.2	3.0	MW	1120-1240
	Lab	LI120	Warren K	1.0		M	1250-0140

_____ or _____

ENGL 420 Reading Improvement

40463	Lec	PB14	Warren K	3.2	3.0	MW	0945-1105
	Lab	SS216	Warren K	1.0		R	0945-1035

and

ENGL 440 Basic Writing

40472	Lec	PB14	Warren K	3.2	3.0	MW	1120-1240
	Lab	LI120	Warren K	1.0		W	1250-0140

CRN	Type	Room	Instructor	Hrs.	Units	Days	Begin-End
-----	------	------	------------	------	-------	------	-----------

All new ESL students must go through the ESL assessment process. See page 109.

Todos los nuevos estudiantes de ESL deben tomar el examen de nivelación de ESL. Consulte la página 109.

ENGLISH AS A SECOND LANGUAGE

ESL 501 Survival ESL I

Transferable: No

This is a course in survival English for students with little or no oral or written English competency. It will give students basic vocabulary and familiarity in life skill areas such as the family, food, health, and occupations. The course integrates listening, speaking, reading, and writing. (ESL 501, 502, and 503 are sequential courses that may be taken in full form or in halves, preferably A before B.) This is a pass/no pass course. ADVISORY: ESL assessment recommendation

40117	L/L	HOL6	Howell J	8.4	6.0	MWF	0810-1040
	L/L	HOL6	Howell J	1.6		T	0810-0930

Above class meets at the Hollister Briggs site.

ESL 502 Survival ESL II

Transferable: No

This is a second course in survival English for students with little oral or written English competency. It will give students expanded basic vocabulary and familiarity in life skill areas such as the weather, transportation, employment, and American holidays and customs. The course integrates listening, speaking, reading, and writing. (ESL 501, 502, and 503 are sequential courses that may be taken in full form or in halved, preferably A before B.) This is a pass/no pass course. ADVISORY: ESL 501 or ESL 501A and 501B or ESL assessment recommendation

40118	L/L	HOL4	Maxwell K	10.0	6.0	MTWRF	0910-1105
-------	-----	------	-----------	------	-----	-------	-----------

Above class meets at the Hollister Briggs site.

ESL 503 Survival ESL III

Transferable: No

This is a third course in survival English for students with beginning oral or written English competency. It will reinforce basic skills learned and continue to develop vocabulary and ease of communication in life skill areas such as the family, the larger community, health, employment, and leisure activities. The course integrates listening, speaking, reading, and writing. (ESL 501, 502, and 503 are sequential courses that may be taken in full form or in halves, preferably A before B.) This is a pass/no pass course. ADVISORY: ESL 502 or ESL 502A and ESL 502B or ESL assessment recommendation.

40148	L/L	HOL4	TBA	10.0	6.0	MTWRF	1115-0110
-------	-----	------	-----	------	-----	-------	-----------

Above class meets at the Hollister Briggs site.

40585	L/L	PB13	Guzman D	10.0	6.0	MTWR	0630-0845
-------	-----	------	----------	------	-----	------	-----------

ESL 510A Basic ESL I

Transferable: No

This is an intensive, integrated-skill course for students with little English. Through listening, speaking, reading and writing activities, students learn to use the structures of English with increasing accuracy, while gaining basic life skills. This is a pass/no pass course. ADVISORY: ESL Assessment Recommendation.

40119	L/L	CJ500	Polizzotto J	9.0	9.0	MTWRF	0810-0940
	ARR		TBA	2.0			
40120	L/L	CJ500	Campbell K	9.0	9.0	MTWRF	0950-1120
	ARR		TBA	2.0			

The Final Word!

Look for the Final Exams schedule on page 105 of this schedule.

CRN	Type	Room	Instructor	Hrs.	Units	Days	Begin-End
-----	------	------	------------	------	-------	------	-----------

ESL 510B Basic ESL II

Transferable: No

This course is a continuation of ESL 510A. This is an intensive, integrated-skill program for students who function in a limited way in English. Through listening, speaking, reading and writing activities, students continue learning to use the structures of English with increasing accuracy, while gaining further basic life skills. This is a pass/no pass course. ADVISORY: ESL 510A or ESL assessment recommendation.

40121	L/L ARR	CJ500	Baameur K TBA	9.0 2.0	9.0	MTWRF	1130-0100
40149	L/L ARR	PH102	Diehl K TBA	9.0 2.0	9.0	MTWRF	0940-1110

ESL 521 Beginning ESL Listening/Speaking

Transferable: No

This course develops basic listening and speaking skills, moving from a functional survival context to academic readiness. Activities are directed at providing practice through listening exercises, role-play, pair work, small and large group discussion, interviews, and oral presentations. ADVISORY: ESL 510B or ESL Assessment Test Recommendation. Recommended concurrent enrollment in ESL 522 and 523.

40131	L/L ARR	PB13	Wexler L TBA	4.2 2.0	4.0	MWF	0810-0920
-------	------------	------	-----------------	------------	-----	-----	-----------

ESL 522 Beginning ESL Reading/Vocabulary

Transferable: No

This course begins the development of reading skills and vocabulary through the application of different reading strategies to a variety of selections on topics of interest to academically-bound students. ADVISORY: ESL 510B or 510C or Assessment recommendation. Recommended concurrent enrollment in ESL 521 and 523.

40132	L/L ARR	PB13	Cisneros N TBA	3.2 2.0	3.0	TR	0810-0930
-------	------------	------	-------------------	------------	-----	----	-----------

ESL 523 Beginning ESL Grammar/Writing

Transferable: No

This is a beginning grammar/writing course for students with very basic grammar. The focus is on basic grammatical structures, punctuation and sentence skills. ADVISORY: ESL 510B or ESL Assessment Test recommendation. Recommended concurrent enrollment in ESL 521 and ESL 522.

40133	L/L ARR	PB12	TBA	5.2 1.0	5.0	MTWR	1110-1215
-------	------------	------	-----	------------	-----	------	-----------

**ESL 528 Integrated Speaking/Listening I**

Transferable: No

This is the first in a series of integrated skills courses designed to develop the listening, speaking and pronunciation skills of beginning ESL students. Activities, which include listening exercises, role-play, pair work, small and large group discussions, interviews, oral presentations and pronunciation drills (focusing on English sounds and rhythm), are presented in the context of relevant, contemporary and intellectually challenging themes. This course is designed especially for students with academic objectives but is highly appropriate for students with personal language goals, as well. PREREQUISITE: ESL 510B or ESL 503 or ESL Assessment recommendation.

40876	Lec	HOL4	TBA	5.7	6.0	MWF	0630-0805
Above class meets at the Hollister Briggs site.							
40879	Lec	PB12	Shelley A	6.0	6.0	TR	0630-0930

ESL 531 Intermediate ESL Listening/Speaking I

Transferable: No

In this course, listening and speaking skills are developed through extended listening exercises, open-ended dialogues, pair and group discussions, oral interviews, and oral reports. Units earned in this course do not count toward the associate degree and/or certain certificate requirements. ADVISORY: ESL 521 or ESL Assessment Test Recommendation. Recommended concurrent enrollment in ESL 532 and 533.

40134	L/L ARR	PB13	Cisneros N TBA	4.2 2.0	4.0	MWF	0945-1055
-------	------------	------	-------------------	------------	-----	-----	-----------

CRN	Type	Room	Instructor	Hrs.	Units	Days	Begin-End
-----	------	------	------------	------	-------	------	-----------

ESL 532 Intermediate ESL Reading/Vocabulary I

Transferable: No

This course continues the development of reading skills and vocabulary through the application of different reading strategies to a variety of selections on topics of interest to academically-bound students. ADVISORY: ESL 522 or ESL Assessment Recommendation. Recommended concurrent enrollment in ESL 531 and 533.

40135	L/L ARR	PB13	Cisneros N TBA	3.2 2.0	3.0	TR	0945-1105
-------	------------	------	-------------------	------------	-----	----	-----------

ESL 533 Intermediate ESL Grammar/Writing I

Transferable: No

This course involves the practice and refinement of sentence and paragraph skills, structure and punctuation. Students will learn basic use of the computer as a writing tool. Units earned in this course do not count toward the associate degree and/or certain certificate requirements. PREREQUISITE: ESL 523 with a grade of C or better or ESL Assessment Test recommendation. ADVISORY: Recommended concurrent enrollment in ESL 531 and ESL 532.

40136	L/L ARR	LI100	Lawn B TBA	5.2 1.0	5.0	MTWR	1225-0130
-------	------------	-------	---------------	------------	-----	------	-----------

ESL 541 Intermediate ESL Listening/Speaking II

Transferable: No

This course expands listening and speaking skills through extended listening exercises, open-ended dialogues, pair and group discussions, oral interviews, and oral reports. Students broaden vocabulary while listening to and speaking in both formal and informal, conversational and academic situations. ADVISORY: ESL 531 or ESL Assessment Recommendation. Recommended concurrent enrollment in ESL 542 and 543.

40137	L/L ARR	PB12	Sanidad M TBA	4.2 2.0	4.0	MWF	1225-0135
-------	------------	------	------------------	------------	-----	-----	-----------

ESL 542 Intermediate ESL Reading/Vocabulary II

Transferable: No

This course begins the expansion of reading skills and vocabulary development through the application of different reading strategies to a variety of selections on topics of interest to academically-bound students including selections from literature. ADVISORY: ESL 532 or ESL Assessment Recommendation. Recommended concurrent enrollment in ESL 541 and 543.

40138	L/L ARR	LI100	Carrillo L TBA	3.2 2.0	3.0	TR	1100-1220
-------	------------	-------	-------------------	------------	-----	----	-----------

ESL 543 Intermediate ESL Grammar/Writing II

Transferable: No

This course is a continuation of ESL 533. Units earned in this course do not count toward the associate degree and/or certain certificate requirements. PREREQUISITE: ESL 533 with a grade of C or better or ESL assessment recommendation. ADVISORY: Recommended concurrent enrollment in ESL 541 and ESL 542.

40139	L/L ARR	LI100	Lawn B TBA	5.2 1.0	5.0	TWRF	0945-1050
-------	------------	-------	---------------	------------	-----	------	-----------

ESL 552 Advanced ESL Reading/Vocabulary I

Transferable: No

This course focuses on academic and critical thinking skills needed to increase reading comprehension and efficiency. Emphasis is on analyzing, making inferences, taking notes, supporting opinions, summarizing and expanding vocabulary. Readings are from academic texts and literature. ADVISORY: ESL 542 or ESL Assessment Recommendation. Recommended concurrent enrollment in ESL 553 and/or ESL 555.

40140	Lec	PB13	Wexler L	2.8	4.0	TR	1225-0135
	Lec	PB13	Wexler L	1.4		F	1115-1225

ESL 553 Advanced ESL Composition I

Transferable: No

This course is a composition course for ESL students that develops college composition skills through a review of the parts and elements of the English paragraph and an introduction to the essay form. The course focuses on the development of a paragraph and expands to the writing of multiple paragraphs in an essay. Basic rhetorical patterns and methods of organization are covered using the multiple-draft approach to writing. PREREQUISITE: ESL 543 with a grade of C or better or ESL Assessment Test recommendation. ADVISORY: Recommended concurrent enrollment in ESL 552 and ESL 554.

40141	L/L ARR	PB12	Campbell K TBA	5.2 1.0	5.0	MTWR	0810-0915
-------	------------	------	-------------------	------------	-----	------	-----------

CRN Type Room Instructor Hrs. Units Days Begin-End

ESL 554 Advanced ESL Grammar I

Transferable: No

This course is designed to help students improve their grammar usage so that they will be able to expand their use of grammar structures in oral and written communication. Students begin the study of more sophisticated grammar structures such as past and future perfect, passive voice, and modal auxiliaries for past time, and they review perfect and modals for present and future time. Students will enhance their understanding of grammar by comparing and contrasting new and previously encountered structures and better appreciate the subtleties of English grammar. **PREREQUISITE:** ESL 543 with a grade of 'C' or better or ESL Assessment Test Recommendation. **ADVISORY:** Recommended concurrent enrollment in ESL 552 and ESL 553.

40150	L/L	PB13	Cisneros N	5.2	5.0	MTWR	1115-1220
	ARR		TBA	1.0			

ESL 562 Advanced ESL Reading/Vocabulary II

Transferable: No

This course prepares ESL students for mainstream college classes by reviewing a variety of reading skills, strategies, and topics from different academic disciplines. Students expand their academic vocabulary and read short stories or a novel for literary appreciation. **ADVISORY:** ESL 552 or ESL Assessment recommendation. Recommended concurrent enrollment in ESL 563.

40143	Lec	LI100	Lawn B	4.2	4.0	MWF	1105-1215
-------	-----	-------	--------	-----	-----	-----	-----------

ESL 563 Advanced ESL Composition II

Transferable: No

This course, which is designed for ESL students, refines and further expands college composition skills through the writing of essays using the multiple-draft approach to writing. The course focuses on the structuring and development of an essay with the use of personal examples. Students write in response to a variety of prompts using different rhetorical patterns such as classification, cause/effect, and comparison/contrast. **PREREQUISITE:** ESL 553 with a grade of "C" or better or ESL Assessment Test recommendation. **ADVISORY:** Recommended concurrent enrollment in ESL 562 and ESL 564.

40145	L/L	PB12	Wexler L	5.2	5.0	TWRF	0945-1050
	ARR		TBA	1.0			

ESL 564 Advanced ESL Grammar II

Transferable: No

This course is designed to expand grammar usage to include adjective, noun, and adverb clauses in oral and written communication. Students learn the meaning and use of clause connectors and are introduced to conditionals, both real and unreal. These grammar structures constitute some of the most complex structures in English and expose students to a rich variety of structures that can effectively enhance their oral and written expression. **PREREQUISITE:** ESL 554 with a grade of 'C' or better or ESL Assessment Recommendation. **ADVISORY:** Recommended concurrent enrollment in ESL 562 and ESL 563.

40152	L/L	LI100	Sanidad M	5.2	5.0	MTWR	0810-0915
-------	-----	-------	-----------	-----	-----	------	-----------

Film: see ENGL 2C, HUM 3, 4, 10

Foreign Language: see French, Japanese, Spanish

FRENCH

FRNH 1B Elementary French

Transferable: CSU, UC; CSU-GE:C2, IGETC:6A; GAV-GE:C2

Continuation of French 1A with further development of the four skills of understanding, speaking, reading, and writing. Continued emphasis on culture. **PREREQUISITE:** French 1A, or equivalent.

40675	Lec	PB12	Sanidad M	6.8	5.0	MTWR	0230-0335
	ARR		TBA	2.8			

FRNH 23 Independent Study

Transferable: CSU

Designed to afford selected students specialized opportunities for exploring areas at the independent study level. The courses may involve extensive library work, research in the community, or special projects. May be repeated until six units of credit are accrued. This course has the option of a letter grade or pass/no pass. **REQUIRED:** The study outline prepared by the student and the instructor must be filed with the department and the dean.

40677	Ind	SS104	Sanidad M	1.0			
-------	-----	-------	-----------	-----	--	--	--

C'est Chic!
Learn French!



FRNH 1B
Elementary French

CRN 40675
Monday-Thursday
2:30-3:55 pm
Instructor: Mary Ann Sanidad

This course satisfies the general education Humanities (Area C-2) requirement under the AA/AS Degree, the CSU-GE Breath pattern, and the language requirement for UC.

Prerequisite: French 1A or equivalent

OVERVIEW
of ESL
COURSES

NON CREDIT

LIFE SKILLS

VOCATIONAL

ESL 777

ESL 778

VESL ESL 704A/B

ESL 779

ESL 780

To move from noncredit to credit ESL classes students must take an ESL assessment.

ESL 781

ESL 782

CREDIT

SURVIVAL TRACK

ACADEMIC TRACK

ESL 501

Basic

510A

ESL 502

510B

ESL 503

Beginning

521 L/S

522R

523GW

Intermediate I

531 L/S

532R

533GW

Intermediate II

541 L/S

542R

543GW

Advanced I

552R

553W

554G

Advanced II

561 L/S

562R

563W

564G

SUPPLEMENTARY
ESL COURSES:

- ESL 546 Intro Computers/ESL
- ESL 556 Intro Competency/ESL
- ESL 581 Pronunciation I
- ESL 582 Pronunciation II
- ESL 584 Culture through Film
- ESL 585 Editing for ESL Writers

ENGL 260

ENGL 250

ACADEMIC
PROGRAMS

or

VOCATIONAL
PROGRAMS

CRN	Type	Room	Instructor	Hrs.	Units	Days	Begin-End
-----	------	------	------------	------	-------	------	-----------

GEOGRAPHY

GEOG 1 Physical Geography

Transferable: CSU, UC; CSU-GE:B1, B3, IGETC:5A; GAV-GE:B1, B3; CAN:GEOG2

An introductory study of the basic physical elements of geography including climate, land forms, soils, water, and natural vegetation. The laboratory will include the tools and methods of geographers. **ADVISORY:** Eligible for English 250 and English 260.

40047	L/L	HOL2	Willahan D	5.4	3.0	MW	0945-1210
-------	-----	------	------------	-----	-----	----	-----------

Above class meets at the Hollister Briggs site.

GEOLOGY

GEOL 1 Introduction to Geology

Transferable: CSU, UC; CSU-GE:B1, B3, IGETC:5A; GAV-GE:B1, B3; CAN:GEOL2

A study of the earth and the physical properties which modify the earth; minerals, rocks, geologic structures and processes. **ADVISORY:** Eligible for English 250 and English 260.

40212	L/L	SS206	Willahan D	6.6	4.0	MW	1250-0355
-------	-----	-------	------------	-----	-----	----	-----------

Government: see Political Science
Graphic Arts: see Art, CSIS, Digital Media

GUIDANCE

GUID 1 Self-Assessment and Career Development

Transferable: CSU; CSU-GE:E2; GAV-GE:E2

This course is designed to assist the student in learning more about personal values, personality, interests, exploration of career choice, and occupational opportunities through the use of various personal assessment instruments. The delivery options for this course also include online and self-paced formats. This course is also listed as PSYC 5. **ADVISORY:** Eligible for English 250 and English 260. \$12 fee will be charged for career assessment materials.

40007	Lec	SS203	Godley J	3.2	3.0	TR	1250-0210
-------	-----	-------	----------	-----	-----	----	-----------

40008	Online		Tenney L		3.0		
-------	--------	--	----------	--	-----	--	--

 This online class will be delivered entirely over the Internet. After enrolling, start the class by going to <http://www.gavilan.edu/disted>, and log into the system. Students who have not logged in by 5 pm on the 3rd day may be dropped from the class.

40006	Lec	HOL5	Caffiero J	3.2	3.0	MW	0400-0520
-------	-----	------	------------	-----	-----	----	-----------

Above class meets at the Hollister Briggs site.

40030	Lec	MHG12	Godley J	3.2	3.0	MW	0400-0520
-------	-----	-------	----------	-----	-----	----	-----------

Above class meets at Morgan Hill Community site.

PUENTE LEARNING COMMUNITY GUID 1 CLASS:

40004	Lec	CH101	Marquez C	3.2	3.0	MW	1120-1240
-------	-----	-------	-----------	-----	-----	----	-----------

Students enrolled in this class will participate in the PUENTE program and will need to complete 10 hours of mentoring. Required: Complete an application with the Puente counselor prior to registration. This class is part part of a learning community. Students must also enroll in ENGL 1A, CRN 40319. See ad on page 75.

GUID 6 Life Skills for Higher Education

Transferable: CSU, UC; CSU-GE:E2; GAV-GE:E2

Evaluation and application of academic study methods to achieve subject matter mastery. Development of critical thinking skills, and application of reading, writing, note taking and test taking methods to improve personal strategies. Exploration of personal lifestyle and health factors, including the causes and management of stress, as it relates to academic success. Assessment of academic and career goals, selection of majors, and development of education plans. Topics covered include creative and realistic goal setting, academic and life management, college and community resources, library and Internet use, time management, and techniques to reduce math and science anxiety. This class will address a multitude of cultural learning styles, with emphasis on attaining professional, personal and academic goals in a diverse society. Topics from developmental psychology, learning theory and personality theory. **ADVISORY:** Eligible for English 250 and English 260.

40033	Lec	APE120/121	Lopez A	2.3	2.0	M	0230-0435
-------	-----	------------	---------	-----	-----	---	-----------

CRN	Type	Room	Instructor	Hrs.	Units	Days	Begin-End
-----	------	------	------------	------	-------	------	-----------

GUID 22 Field Work and Service

Transferable: CSU

Supervised field work within the college and with local agencies. Students serve in useful group activities in leadership roles prescribed for them by faculty or community agencies. A maximum of six units may be completed. This is a pass/no pass course. **REQUIRED:** Learning contracts must be filled out and signed by the student and the supervising instructor.

40287	Fld Ex	LI117	Eastman B		1.0		
-------	--------	-------	-----------	--	-----	--	--

Contact the Disability Resource Center (DRC) Office.

GUID 28 Tutoring Techniques

Transferable: CSU

This course is designed to train students in effective tutoring skills, introduction to how people learn, teaching to modalities, and techniques of working with student anxiety. This course has the option of a letter grade or pass/no pass. **ADVISORY:** English 250.

40014	Lec	SS110	King D	2.0	1.0	F	1100-1240
	Lec	LI116	TBA	4.0		S	0930-0130

02/20/09 - 04/03/09 Please contact Debbie King at the Tutoring Center in LI116 or call 408-848-4838 upon enrolling in this class. Class meets seven Fridays, Feb 20-Apr 3, and ONLY ONE Saturday, Feb 28.

GUID 29 Tutoring Lab

Transferable: CSU

This course will allow students to gain valuable experience in the field of teaching. Students will practice the skills they have learned in Guidance 28. Guidance 29 may be repeated for a maximum of 2.0 units per semester and a maximum course total of 8.0 units. This is a pass/no pass course. **ADVISORY:** Completion of, or concurrent enrollment in Guidance 28.

40015	Lab	LI116	King D		1.0		
-------	-----	-------	--------	--	-----	--	--

This is an open entry-open exit class.

40016	Lab	LI116	King D		1.0		
-------	-----	-------	--------	--	-----	--	--

This is an open entry-open exit class.

GUID 191A Workplace Skills

Transferable: CSU

Workplace Skills teaches skills vital to workplace success. The topic for 191A is Interpersonal Communication. Need not be taken in sequence. This is a pass/no pass course.

41033	Lec	BU110	TBA		1.0		
-------	-----	-------	-----	--	-----	--	--

GUID 191B Workplace Skills

Transferable: CSU

Workplace Skills teaches skills vital to workplace success. The topic for 191B is team building. Need not be taken in sequence. This is a pass/no pass course.

41003	Lec	BU120	Arteaga B	10.0	1.0	MTWRF	0900-1100
-------	-----	-------	-----------	------	-----	-------	-----------

05/28/09 - 06/10/09

GUID 250 Supervised Tutoring

Transferable: No

Laboratory class emphasizing college learning skills, appropriate study techniques, and learning assistance utilizing one-on-one or small group tutorial. Guid 250 is a non-credit class and will not appear on a student's transcript.

40021	Lab	LI116	TBA				Tutoring Center
40022	Lab	LI116	TBA				Tutoring Center
40023	Lab	LI168	TBA				Computer Place
40024	Lab	LI168	TBA				Computer Place
40025	Lab	LI120	TBA				Writing Center
40026	Lab	LI126	TBA				Digital Media Lab
40027	Lab	PH101	TBA				Math Lab
40028	Lab	HOB104	TBA				Health Occupations Lab
40029	Lab	HOB104	TBA				Health Occupations Lab

CRN Type Room Instructor Hrs. Units Days Begin-End

GUID 530 Job Readiness

Transferable: No

This course is designed to provide a comprehensive, well-organized approach to assist individuals with the identification of occupational choices and the development of job readiness skills necessary to obtain and maintain employment in a competitive or supported work setting. May be repeated twice for credit. This course has the option of a letter grade or pass/no pass.

40288 Lec APE120/121 Franklin L 3.2 3.0 TR 0945-1105

GUID 557 Learning Skills Assessment

Transferable: No

This course provides an assessment of the students' cognitive/perceptual abilities and basic skills academic achievement. The assessment results are used to determine the students' eligibility for Learning Disabilities Services, to develop individual educational plans, and/or to improve the students' understanding of their own learning strengths and weaknesses. The assessment is conducted on a one-to-one basis by appointment. Units earned in this course do not count toward the associate degree and/or certificate requirements. This is a pass/no pass course.

40289 Lab LI117 Burgman L .5
Overson R

Open Entry-Open Exit. Make an appointment with the Disability Resource Center (DRC) Office.

GUID 558 Learning Skills Laboratory

Transferable: No

The Learning Skills Laboratory is designed to assist students who are eligible to receive Learning Disabilities Services and/or have demonstrated academic deficits. The course content is individualized and based on Student Educational Contracts which are developed for each student. Students receive supplemental instruction, academic support, and learning strategy suggestions appropriate for their individual cognitive, perceptual, and academic strengths and weaknesses. Units earned do not count towards the associate degree and/or certificate requirements. This is a pass/no pass course. ADVISORY: Completion of Guidance 557 or demonstrated academic deficit.

40290 Lab LI116 Overson R .5
Burgman L

Open Entry - Open Exit

40291 Lab LI116 Overson R 1.0
Burgman L

Open Entry - Open Exit

40292 Lab LI116 Overson R 2.0
Burgman L

Open Entry - Open Exit

GUID 561 Writing Skills

Transferable: No

This course is designed to teach basic writing skills to students who have demonstrated difficulty mastering written language and who are eligible to receive Learning Disability Services. Material is presented in a concrete, multi-sensory manner, and the class includes opportunity for immediate practice, repetition, and review. The course content includes grammar, sentence structure, and punctuation. Units earned do not count toward the associate degree and/or certificate requirements. This course has the option of a letter grade or pass/no pass. ADVISORY: Completion of Guidance 557 or demonstrated deficit in written language achievement. Recommended for students with verified learning disability.

40293 L/L BU117 Maringer J 2.0 1.0 TR 1120-1220

GUID 562 Directed Study Lab in Arithmetic

Transferable: No

This course is designed for students who have demonstrated difficulty in mastering arithmetic and who are eligible to receive Learning Disability Services. Course content parallels Mathematics 400. Material is presented in a concrete, multi-sensory manner, and the lab allows opportunity for immediate practice, questions, repetition, and review. Units earned do not count toward the associate degree and/or certificate requirements. This is a pass/no pass course. COREQUISITE: Concurrent enrollment in MATH 400. ADVISORY: Completion of GUID 557 and/or a demonstrated deficit in arithmetic. Recommended for students with verified learning disability.

40294 Lab SS216 Burgman L 3.2 1.0 TR 1120-1240



Service Learning
for community social change

Would you like to raise your grades, connect class material with the real world, and help somebody else as you become culturally competent in your own community? **Try a Service Learning class!** These classes allow you to work at a community non-profit partner agency as part of your coursework, and help you see how academic material applies in your own community!

The following spring 2009 courses at Gavilan will offer Service Learning:

AJ 6	Intro. to Conflict Resolution	40972	Lec	SS110	3 units	TR	1250-0210
ANTH 3	Intro. to Cultural Anthropology	40043	Lec	SS205	3 units	MW	0230-0350
ART 14	Beginning Mural Painting	40621	L/L	PB8	3 units	F	0900-0105 + 2 arranged hours
CD 8B	Teaching Reading/Writing to Children	40596	Lec	MHG4	3 units	R	0600-0905
CMUN 6	Intro. to Conflict Resolution	40975	Lec	SS110	3 units	TR	1250-0210
CMUN 10	Small Group Communication	40666	Lec	PB1	3 units	MW	1250-0210
		40667	Lec	PB1	3 units	M	0500-0805
		40668	Lec	PB1	3 units	MW	0945-1105
ECOL 1	Conservation of Natural Resources	40982	Lab	LS102		S	0900-1205
ENGL 250	Practical Writing	40415	Lec	PB3	3 units	MW	0810-0930
			Lab	LI120		T	0810-0900
		40417	Lec	PB3	3 units	MW	0810-0930
			Lab	LI120		R	0810-0900
POLS 1	Intro. to American Government	40085	Lec	SS210	3 units	F	0230-0535
		40086	Lec	SS210	3 units	M	0600-0905
POLS 6	Intro. to Conflict Resolution	40091	Lec	SS110	3 units	TR	1250-0210
PSYC 6	Intro. to Conflict Resolution	40103	Lec	SS110	3 units	TR	1250-0210
SOC 1B	Intro. to Sociology: Social Problems	40111	Lec	SS205	3 units	MW	0945-1105



The Puente Project is a two-semester program that combines three components: writing, counseling and mentoring to support students to transfer to four-year universities and colleges. The Guidance 1 course focuses on self assessment and career development. The English 1A course focuses on Mexican American/Latino literature. The program also includes a student leadership conference, university visits and mentor/student socials. The program is open to all eligible students. For more information, call Celia Marquez, Puente Co-Coordinator at 408-848-4807.

Required: Complete a program application with the Puente Counselor prior to registration.

ENGL1A CRN 40319 SS206 SANDLER S TuTh 1120A-1240P

GUID 1 CRN 40004 CH101 MARQUEZ C MW 1120A-1240P
Students will need to complete 10 hours of mentoring.

CRN	Type	Room	Instructor	Hrs.	Units	Days	Begin-End
-----	------	------	------------	------	-------	------	-----------

GUID 563A Directed Study Lab in Algebra**Transferable:** No

This course is designed for students who have demonstrated difficulty mastering elementary algebra and who are eligible to receive Learning Disability Services. Course content parallels Mathematics 205A. Material is presented in a concrete, multi-sensory manner, and the lab allows opportunity for immediate practice, questions, repetition, and review. This is a pass/no pass course. **COREQUISITE:** Concurrent enrollment in MATH 205A is required. **ADVISORY:** Completion of GUID 557 or demonstrated deficit in mathematics. Recommended for students with verified learning disability.

40868	Lab ARR	APE120/121	Overson R TBA	3.2	1.0	MW	0945-1105
-------	------------	------------	------------------	-----	-----	----	-----------

GUID 563B Directed Study Lab in Algebra**Transferable:** No

This course is designed for students who have demonstrated difficulty mastering elementary algebra and who are eligible to receive Learning Disability Services. Course content parallels Mathematics 205B. Material is presented in a concrete, multi-sensory manner, and the lab allows opportunity for immediate practice, questions, repetition, and review. This is a pass/no pass course. **COREQUISITE:** Concurrent enrollment in MATH 205B is required. **ADVISORY:** Completion of GUID 557 or demonstrated deficit in mathematics. Recommended for students with verified learning disability.

40295	Lab ARR	APE120/121	Overson R TBA	3.2	1.0	MW	1120-1240
-------	------------	------------	------------------	-----	-----	----	-----------

GUID 564 Directed Study Lab in Pre-Algebra**Transferable:** No

This course is designed for students who are eligible to receive Learning Disability Services and/or who have demonstrated difficulty in mastering pre-algebra. The course content parallels Mathematics 402. The material is presented in a concrete, multi-sensory manner, and the lab environment allows opportunity for immediate practice questions, repetition and review. Units earned do not count towards the associate degree and/or certificate requirements. This is a pass/no pass course. **COREQUISITE:** Concurrent enrollment in MATH 402. **ADVISORY:** Completion of Guidance 557 and/or a demonstrated deficit in Mathematics. Recommended for students with verified learning disability.

40296	Lab	BU117	Burgman L	3.2	1.0	MW	1120-1240
-------	-----	-------	-----------	-----	-----	----	-----------

HEALTH EDUCATION**HE 1 Health Education****Transferable:** CSU, UC; CSU-GE:E2; GAV-GE:E2

This course focuses on attaining individual awareness, critical-thinking skills and self-responsibility relating to personal health. The interaction of individual physical, psychological, social, emotional, spiritual and environmental factors in determining health status is developed through integration of major concepts. This course has the option of a letter grade or pass/no pass. **ADVISORY:** Eligible for English 250 and English 260.

40826	Lec	LS106	Dodd S	3.2	3.0	TR	0945-1105
-------	-----	-------	--------	-----	-----	----	-----------

40828	Online		Quatre S		3.0		
-------	--------	--	----------	--	-----	--	--

 This online class will be delivered entirely over the Internet. After enrolling, start the class by going to <http://www.gavilan.edu/disted>, and log into the system. Students who have not logged in by 5 pm on the 3rd day may be dropped from the class.

40829	Online		Quatre S		3.0		
-------	--------	--	----------	--	-----	--	--

 This online class will be delivered entirely over the Internet. After enrolling, start the class by going to <http://www.gavilan.edu/disted>, and log into the system. Students who have not logged in by 5 pm on the 3rd day may be dropped from the class.

HE 2 Human Sexuality**Transferable:** CSU, UC; CSU-GE:E2; GAV-GE:E2

Assists students in gaining increased knowledge, appreciation, and respect for their own sexuality, as well as others. Approved by the Board of Registered Nursing for 54 hours of continuing education credit (Provider #00892). **ADVISORY:** Eligible for English 250 and English 260

40830	Lec	LS106	Logan C	3.2	3.0	MW	0945-1105
-------	-----	-------	---------	-----	-----	----	-----------

40831	Online		Quatre S		3.0		
-------	--------	--	----------	--	-----	--	--

 This online class will be delivered entirely over the Internet. After enrolling, start the class by going to <http://www.gavilan.edu/disted>, and log into the system. Students who have not logged in by 5 pm on the 3rd day may be dropped from the class.

CRN	Type	Room	Instructor	Hrs.	Units	Days	Begin-End
-----	------	------	------------	------	-------	------	-----------

HISTORY**HIST 1 United States History through Reconstruction****Transferable:** CSU, UC; CSU-GE:C2, D6, IGETC:3B, 4F, 7B; GAV-GE:C2, D2; CAN:HIST8, HIST SEQ B

History of the United States from the time before European contact with the Americas through Reconstruction. Emphasis will be placed on distinctive patterns of political, economic, social, intellectual, and geographic developments within their global context. At the conclusion of the course, the student should understand major themes in the history of the United States, and be able to explain various ways in which ideas about federal vs. state power, ethnicity, class, and gender divisions have influenced the nation's development. This course has the option of a letter grade or pass/no pass. **ADVISORY:** Eligible for English 250 and English 260.

40048	Lec	MHG12	Mosher C	3.2	3.0	MW	0810-0930
-------	-----	-------	----------	-----	-----	----	-----------

Above class meets at Morgan Hill Community site.

40049	Lec	SS210	Luna E	3.2	3.0	MW	0945-1105
-------	-----	-------	--------	-----	-----	----	-----------

40050	Lec	SS214	Luna E	3.2	3.0	MW	1250-0210
-------	-----	-------	--------	-----	-----	----	-----------

40051	Lec	HOL5	Luna E	3.3	3.0	T	0600-0905
-------	-----	------	--------	-----	-----	---	-----------

Above class meets at the Hollister Briggs site.

40053	Lec	MHG4	Mosher C	3.3	3.0	W	0600-0905
-------	-----	------	----------	-----	-----	---	-----------

Above class meets at Morgan Hill Community site.

40129	Online		Guardino L		3.0		
-------	--------	--	------------	--	-----	--	--

 This online class will be delivered entirely over the Internet. After enrolling, start the class by going to <http://www.gavilan.edu/disted>, and log into the system. Students who have not logged in by 5 pm on the 3rd day may be dropped from the class.

HIST 2 United States History Reconstruction to the Present**Transferable:** CSU, UC; CSU-GE:C2, D6, IGETC:3B, 4F, 7B; GAV-GE:C2, D2; CAN:HIST10, HIST SEQ B

History of the United States from Reconstruction to the present. Emphasis will be placed on distinctive patterns of political, economic, social, intellectual, and geographic developments within their global context. At the conclusion of the course, the student should understand major themes in the history of the United States, and be able to explain various ways in which ideas about federal vs. state power, ethnicity, class, and gender divisions have influenced the nation's development. This course has the option of a letter grade or pass/no pass. **ADVISORY:** Eligible for English 250 and English 260.

40055	Lec	SS210	Guardino L	3.3	3.0	F	0810-1115
-------	-----	-------	------------	-----	-----	---	-----------

40056	Lec	MHG12	Mosher C	3.2	3.0	MW	1120-1240
-------	-----	-------	----------	-----	-----	----	-----------

Above class meets at Morgan Hill Community site.

40061	Lec	SS210	Halper L	3.2	3.0	MW	0230-0350
-------	-----	-------	----------	-----	-----	----	-----------

40063	Lec	SS214	Halper L	3.2	3.0	TR	0945-1105
-------	-----	-------	----------	-----	-----	----	-----------

40064	Lec	SS210	Luna E	3.2	3.0	TR	1250-0210
-------	-----	-------	--------	-----	-----	----	-----------

40065	Lec	SS210	Halper L	3.3	3.0	R	0600-0905
-------	-----	-------	----------	-----	-----	---	-----------

HIST 4A History of World Societies, Before 1500**Transferable:** CSU, UC; CSU-GE:C2, D6, IGETC:3B, 4F; GAV-GE:C2, D2

A study of major elements in the development of and interactions between world societies, from the first organization of community to the dawn of the Renaissance. Students will comparatively analyze social, cultural, geographic, economic, demographic, technological, environmental, and political developments that moved humans from nomadic to agri-technological and urban lives. This course has the option of a letter grade or pass/no pass. **ADVISORY:** ENGL 250 and ENGL 260.

40066	Lec	SS110	Halper L	3.2	3.0	MW	1120-1240
-------	-----	-------	----------	-----	-----	----	-----------

HIST 5 Women's Lives in Early United States History**Transferable:** CSU, UC; CSU-GE:C2, D4, D6, IGETC:3B, 4F; GAV-GE:C2, D1, D2, F

This survey course begins with pre-contact peoples and extends to the end of the nineteenth century. The class examines the construction of womanhood through United States history, and the effects of gender, ethnicity, class, and sexual orientation upon women's experiences. Students will study the contributions of various individual women and groups of women in creating the modern United States, and will analyze social, political, economic, and cultural forces affecting women to both join and resist movements for social change. Students will also learn to apply contemporary feminist theory to traditional historical approaches. This course has the option of a letter grade or pass/no pass. **ADVISORY:** Eligible for English 250 and English 260.

40067	Lec	SS205	Guardino L	3.3	3.0	T	0600-0905
-------	-----	-------	------------	-----	-----	---	-----------

CRN Type Room Instructor Hrs. Units Days Begin-End

HIST 7B History of Western Civilization

Transferable: CSU, UC; CSU-GE:C2, IGETC:3B; GAV-GE:C2; CAN:HIST4, HIST SEQ A

A study of major elements in western heritage from Renaissance Europe to the present. Emphasis is on ideas, attitudes and institutions basic to western civilization of enduring interest. **ADVISORY:** Eligible for English 250 and English 260.

40068 Lec SS205 Kier D 3.2 3.0 TR 0810-0930

HIST 12 Cultural History of the Mexican American

Transferable: CSU, UC; CSU-GE:C2, D3, D6, IGETC:3B, 4F; GAV-GE:D2, F

The Mexican American experience as influenced by society in the United States. Emphasis will be on the historical and contemporary contributions made by the Indian, Spanish, Mexican, and Mexican American. Emphasis will also be on the social, economic, and political milieu of the Mexican American within the context of the American society. This course has the option of a letter grade or pass/no pass. **ADVISORY:** Eligible for English 250 and English 260.

40070 Lec SS210 Luna E 3.2 3.0 TR 1120-1240

HIST 21 Ancient Americas: A History through Art

Transferable: CSU, UC; CSU-GE:C1, C2, IGETC:3A; GAV-GE:C2, F

A critical survey of history through the arts of pre-Columbian natives of North, Central and South America. The course will cover major societies and events from the appearance of major civilizations through the initial colonization efforts of European nations. Due to the distinct history of the Americas, this course uses the arts - architecture, sculpture, ceramics and painting, among others - of ancient societies as a primary source material. This course has the option of a letter grade or pass/no pass. This course is also listed as ART 21. **ADVISORY:** Eligible for English 250.

40839 Lec SS214 TBA 3.3 3.0 M 0600-0905

HUMANITIES

HUM 4 Introduction to American Cinema

Transferable: CSU, UC; CSU-GE:C2, IGETC:3B; GAV-GE:C2

This introductory course in film studies is a survey of the American film industry as an art form, as an industry, and as a system of representation and communication. The course explores how Hollywood films work technically, aesthetically, and culturally to reinforce and challenge America's national self-image. **ADVISORY:** English 440

40477 Online Richards G 3.0

 This online class will be delivered entirely over the Internet. After enrolling, start the class by going to <http://www.gavilan.edu/disted>, and log into the system. Students who have not logged in by 5 pm on the 3rd day may be dropped from the class.

HUM 10 Approaches to Contemporary Film

Transferable: CSU, UC; CSU-GE:C1, C2, IGETC:3B; GAV-GE:C1, C2

Approaches to Contemporary Film examines theories of film criticism as they apply to films from 1960 to the present. Students learn technical, visual, classical, historical, cultural, ideological, and aesthetic approaches to film and sample from a representative list of foreign and domestic movies. Special emphasis is given to new voices from non-American sources and to emerging voices in American cinema. **ADVISORY:** Eligibility for English 250 and 260.

40478 Lec SS214 Richards G 3.2 3.0 MW 1120-1240

40479 Lec SS214 Richards G 3.2 3.0 TR 1250-0210

HUM 23 Independent Study

Transferable: CSU

Designed to afford selected students specialized opportunities for exploring areas at the independent study level. The courses may involve extensive library work, research in the community, or special projects. May be repeated until six units of credit are accrued. This course has the option of a letter grade or pass/no pass. **REQUIRED:** The study outline prepared by the student and the instructor must be filed with the department and the dean.

40480 Ind PB11 Richards G 1.0

40481 Ind PB11 Richards G 2.0



View films from categories such as:
Musical
War
Film Noir
Western
Comedy
Adventure
Fantasy/Horror
Silent
Suspense & Intregue

Now offered **Online**

Day of Beauty

for Men & Women

Includes:

- ✓ Hair cut & style
 - ✓ Deep conditioning
 - ✓ Scalp treatment
 - ✓ Manicure
 - ✓ Facial
 - ✓ Eyebrow arch
 - ✓ Makeup
- no substitutions*

only **\$30**

w/o coupon - \$35

DISCOUNTS

Senior Citizens: 20% daily

Staff/Students: 10% daily

Discounts not applicable to DAILY SPECIALS, Special perms or any service under \$6.00

Spring/Fall hours

Wed.-Fri. 10:00 am - 2:30 pm

Summer hours

Tu.-Th. 10:30 am - 3:30 pm

DAILY SPECIALS

Wednesday:

Hair Cut ONLY - \$5.50

Hair Cut & Style - \$10

Thursday/Friday:

All Basic Perms - 20% off

Plain Manicure & Pedicure - \$11

Wednesday/Friday:

Hair Color - 20% off

All work performed by students supervised by instructors. Discounts not applicable to daily specials, special color, special perms or any service under \$6. Not valid with any other discounts.

For appointments call 408-842-5055